

HA20 RTJ PRO



PERFORMANCE & EASE OF USE

- > Best lifting speed of 48 sec.
- > Industry leading working envelope with an outreach of 12.2 m
- > Fully proportional and simultaneous movements
- > Ease of transport

EXCELLENT ROBUSTNESS

- > Rugged hoods with ergonomic handle
- > Long lasting structural design

MINIMIZED TOTAL COST OF OWNERSHIP

- > Haulotte Activ'Screen (on board diagnostic)
- > Haulotte Stop Emission System: automatically turns the engine off & on
- > Exclusive modular basket with upper control box cover and tool tray
- > Easy access to all components

BEST COMFORT AND SAFETY FEELING

- > Haulotte Activ'Shield Bar 2.0



HA20 RTJ PRO

ROUGH TERRAIN ARTICULATING BOOMS

TECHNICAL DATA

HA20 RTJ PRO

| | |
|-------------------------------------|-----------------------------------|
| Working height | 20.6 m |
| Platform height | 18.6 m |
| Horizontal outreach | 12.2 m |
| Up and over clearance | 8.4 m |
| Lift capacity | 230 kg (2 pers.) |
| F x G Platform size | 2.44 x 0.91 m |
| A Length - stowed | 8.8 m |
| B Width | 2.42 m |
| Height - stowed | 2.51 m |
| H Storage / transport length | 6.5 m |
| C Storage / transport height | 2.93 m |
| Vertical jib rotation | 140° (+ 60° / - 80°) |
| Platform rotation | 180° (+ 90° / - 90°) |
| Turntable rotation | 360° continuous |
| Tailswing | 14.2 cm |
| D Wheelbase | 2.45 m |
| E Ground clearance | 42 cm |
| Tilt | 5° |
| Drive speed | 0,5 - 5 km/h |
| Gradeability | 45 % |
| Tyres - solid rough terrain | 1025 x 365 mm |
| Turning radius - outside | 3,75 m |
| Power source | Kubota, 36.5kW (49.6hp), Stage 3A |
| Weight | 9 600 kg |

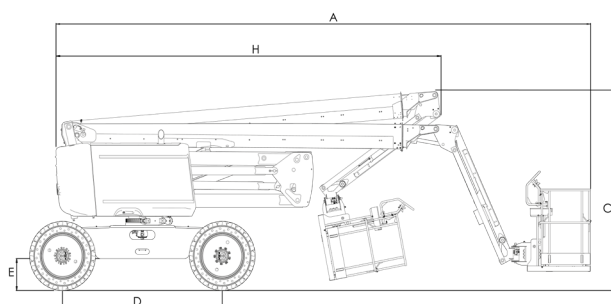
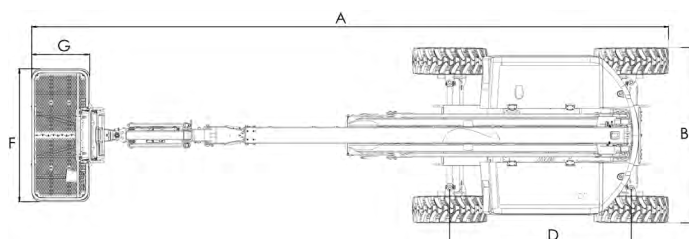

STANDARD EQUIPMENT

- > Haulotte Activ'Screen
- > Haulotte Activ'Shield Bar 2.0
- > Haulotte Stop Emission System
- > Universal telematics plug
- > Rotating beacon
- > Front oscillating axle increases stability on uneven ground
- > 4 wheel drive, 4 wheel steer
- > Permanent limited slip differential
- > 4 simultaneous movements for maximum productivity
- > Large modular basket 2.44 m x 0.91 m, lateral swing door entry gate
- > Upper control box protection cover and tool tray in ultra-solid plastic
- > AC power to platform 110 / 230 V (option for AUS / NZ)
- > Travel alarm
- > Electric pump system and emergency descent
- > 12 V battery
- > Sound and light alarm for tilt and load
- > Hour meter
- > Low fuel level indicator (upper & lower control boxes)
- > Swing out engine tray for ease of maintenance

OPTIONS AND ACCESSORIES

- > Glazier pack
- > Non-marking tyres (standard in AUS / NZ)
- > Biodegradable hydraulic oil
- > Hot weather kit: hydraulic oil cooler + hydraulic oil
- > Cold weather kit: - 10°C / - 25°C
- > Flashing light (standard in AUS / NZ)
- > Power to platform 110 / 230 V (with or without circuit-breaker 30 mA)
- > 55 W working light
- > Air-line to platform 6.5 mm inner diameter
- > Hydraulic generator Dynaset 6.5 kVA (standard in AUS / NZ)
- > Drop entry gate
- > Small basket 1.83 m x 0.91 m
- > Spark arrestor and electric one-way valve

